



# **FLOORING CONSIDERATIONS FOR DAIRY COWS<sup>1</sup>**

**Curt A. Gooch, P.E.**  
Senior Extension Associate  
Department of Biological and Environmental Engineering  
PRO-DAIRY Program  
Cornell University

## **Introduction**

Many aspects of a dairy cow housing barn influence the overall environment experienced by the cows. One of the major aspects is the flooring system employed. Cows housed in modern freestall barns spend 10 to 12 hours per day on their feet. Lameness is a consistent problem with confined dairy cows and represents one of the major reasons cows are culled from the herd. When lameness is not controlled, dairy producers suffer substantial economic loss. Lameness has been shown to be followed by delayed estrus, poor breeding performance, shortened lactation, low yield of milk fat and a sudden drop in body weight (Dewes, 1978), all of which cost the dairy producer money. Poor quality floors can be a major contributor to lameness.

Experience has shown that attention to detail is required during the construction process to provide a cow-friendly floor. Characteristics of a floor that can be used to define it as cow-friendly include a floor that:

1. provides a relatively dry walking surface,
2. provides confident and comfortable footing, and
3. is durable.

Additionally, intuition tells us that at least a portion, if not all, of the flooring surface should have resilient characteristics in order to offer a cow reprieve from hard concrete.

Floors also need to be designed and constructed so they are structurally sound. This will ensure that original floor characteristics will last for some time.

## **Cows and Concrete Floors**

Concrete floors that are roughened in an attempt to preclude slippage can wear hooves excessively, and smooth floors do not offer sufficient traction. There is a fine line between a concrete floor surface that is too rough and causes injury due to abrasion and one that is too smooth and causes injury because of inadequate footing. Experience has shown that the finish on a floor is often the biggest mistake made during barn construction. Rough finished floors will speed foot wear by up to 20 percent, with cows being culled in three weeks of new barn occupancy due to lameness (Bray, 1998).

<sup>1</sup>Written for presentation at the Natural Resource, Agriculture, and Engineering Service (NRAES) conference: Building Freestall Barns and Milking Centers: Methods and Materials held February, 2003

Desirable characteristics of a grooved concrete floor include:

1. Flat surface between grooves,
2. Smooth surface between grooves,
3. Smooth groove edges with a right angle between the groove and the floor surface, and
4. Proper groove width, spacing, and depth.

### **Cast-In-Place Concrete Floors**

By far, the most prevalent flooring surface in new and older barns alike is cast-in-place concrete. Concrete is attractive to use because it is durable, economical, relatively easy to place, conforms to irregular areas well, and can be finished in various ways to provide some level of traction to dairy cows. Traction by the cow is traditionally provided by creating parallel grooves or groove patterns in the concrete surface. In special instances, anti-slip aggregates applied to the concrete surface and epoxy floor coatings can also be utilized.

In many cases the method employed to provide traction for cows is based on a producer's or contractor's individual experiences and preferences and/or the tools currently in-hand to accomplish the task. While this may be acceptable in some cases, it is generally best if the design of the floor finish is based on enhancing the traction offered to the cow by maximizing characteristics of the cow's sole that are largely responsible for her overall stability.

In determining how to best provide traction for cows, the recommended dimensions, orientation, and configuration of grooves and patterns should be known. Then this information can be used to determine how to best apply grooves or patterns to a concrete surface.

#### Groove Dimensions, Orientation, and Configuration

There is a lack of consensus between references reviewed regarding the most appropriate dimensions, orientation and configuration of grooves or patterns installed in concrete to create a slip resistant floor. It appears that two schools of thought exist relative to grooving concrete.

The first theory is to space grooves in such a way that they provide an edge to catch a cow's hoof after slippage initiates. For example, Albright (1995) reports that grooves can be spaced from 4 to 8 inches apart. MWPS-7 (2000) recommends that 1/2 to 1 inch wide parallel grooves with a depth of up to 3/8 inch should be spaced 4 to 5 inches on center with alignment parallel to alley length when flushing or alley scrape manure removal is used. If a diamond pattern is desired, MWPS-7 (2000) indicates it can be constructed using the same groove dimensions with the spacing adjusted to 6 inches on center. Bray (1998) reports that grooves should be 1/2 inch wide and 3/8 inch deep, spaced 3-3/4 inches on center; grooves should be first cut parallel to the longitudinal direction of the alley and then cross-grooved.

With grooves spaced at these distances, slippage may occur before the hoof contacts a groove.

The other theory is to space grooves closer together so that at least one of the four primary hoof contact surfaces lands in a groove when a foot is put down, preventing initial slip. This theory is based on research conducted by Dumelow (1993). Dumelow looked at the slippage of a simulated hoof on various grooved concrete surfaces topped with dairy manure. Dumelow concluded the following for creating a floor that provides confident footing.

1. Space parallel grooves 1.5 inches apart.
2. Grooves lateral to the cow's backbone produce less slip than longitudinal grooves.
3. Maximum traction is provided by creating a regular pattern of hexagons with sides of 1.8 inches in length, as shown in Figure 1.
4. Groove width should not exceed 0.40 inches.

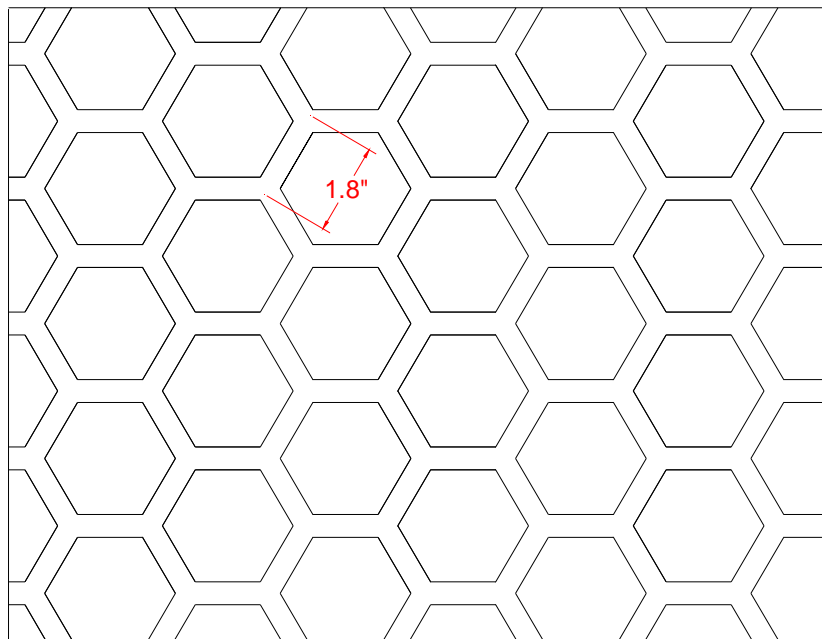

**Figure 1. Plan view of a hexagonal pattern for a concrete floor.**

In practice, creating a hexagonal pattern in concrete is difficult to properly accomplish. Orientating parallel grooves perpendicular to the length of an alley will maximize their effectiveness for cows, but may compromise manure removal. Graves et al. (1997) recommends installing 3/8 to 1/2 inch wide by 3/8 to 1/2 inch deep grooves spaced 2 to 3 inches on center parallel to the direction of scraper travel. The recommended dimensions for parallel grooving a concrete alley in one direction are shown in Figure 2.

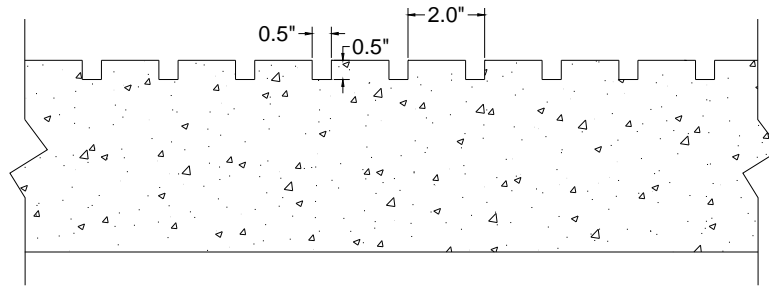

**Figure 2. Cross sectional view of a parallel grooved concrete floor with recommended dimensions.**

Parallel grooves can be created while concrete is setting up or after it has initially cured. Stamped patterns are created while the concrete is still green. Each method is discussed below along with its respective advantages and disadvantages.

### Parallel Grooves In Green Concrete

Bullfloating is a standard task that is performed when constructing concrete slabs-on-grade after screeding takes place. The primary purpose of bullfloating concrete is to eliminate high and low spots (bird baths) and to embed large aggregate particles below the finished surface.

Commercially available bronze grooving attachments can be attached to standard bullfloats and be used to create grooves in freshly placed concrete. By using many of these grooving attachments at once on a bullfloat, parallel grooves can be created. Thumbscrews on each attachment allow for lateral adjustment relative to the bullfloat allowing the bullfloat operator to change the distance between grooves as needed. Grooves can also be installed with a homemade beveled groover fabricated from plywood and wood strips (see MWPS-7 [2000] for details).

Proper moisture content of the concrete makes for easier grooving by the bullfloat operator and results in a quality finished product. Bullfloating grooves should be formed after the concrete has been placed and screeded but before any excess bleed water accumulates on the surface (when normal bullfloating should occur). When the concrete is too wet, the bullfloat is hard to operate due to increased resistance and the grooves tend to fill in with the recently displaced concrete. When the concrete is too dry, the grooving attachments will not fully penetrate the concrete surface, resulting in less than desirable groove depths, exposed aggregates along the edge of the grooves, and consequently a poorly finished product.

Practical experience is needed in order to become proficient at creating a quality grooved floor with the bullfloat grooving method. After experience is obtained, a worker can groove a floor rather rapidly compared to installing grooves with the stamp method (discussed below). However, even experienced crews can fall behind in their work because of erratic delivery of ready-mix concrete to the job site, resulting in a poor grooving job. Another plus for floating grooves versus stamping is due to the inherent nature of the bullfloat tool: the concrete material displaced by each attached groover is

smoothed by the bullfloat passing over the surface of the concrete. This produces grooves without sharp or rough edges and exposed aggregates.

The cost to install parallel grooves in one direction by this method varies between 10 and 20 cents per square foot.

### Cut Grooves

New concrete floors can also be grooved after initial curing takes place. Older concrete floors can be re-grooved as needed to enhance traction. A saw similar to that used to cut expansion joints in concrete roadways can be adapted with a series of diamond data blades to cut grooves in cured concrete.

Cutting grooves in hardened concrete eliminates the need for the concrete contractor to have experience with grooving wet concrete and the requirement for time-sensitive completion. Concrete slabs-on-grade for use as barn alleys can be placed, screeded, floated, and lightly troweled to provide satisfactory results by readily available concrete finishing crews. Then, another contractor that specializes in grooving concrete alleys can be hired.

Dairy producers report that the cost to have parallel grooves cut into initially cured concrete is 40 cents per square foot for grooving in one direction and 80 cents per square foot for two-directional grooving.

### Stamped Patterns

Diamond and hexagonal patterns can be created in green concrete by using a metal stamp. Usually, the metal stamp is fabricated from round stock material that is cut and meticulously welded together. The stamp has a metal handle assembly attached, allowing it to be pushed into and removed from the concrete surface while workers are in a standing position. The stamp must be moved several times to fully pattern a barn alley. A stamp is one possible way to create the hexagonal pattern recommended by Dumelow.

Personal experience has shown that stamping concrete is more difficult to accomplish properly than bullfloat grooving, and stamping is very sensitive to concrete moisture conditions. Concrete that is too wet will tend to stick to the stamp causing undesirable rough edges and a sloppy finish. Concrete that is too dry will bulge up in the inner space between each round stock member used to form the pattern. This bulging of concrete results in the floor having several convex areas that do not uniformly support cows' hooves. Also, when the concrete bulges, it usually cracks on the surface. The quantity of cracks and their size depend on the moisture content of the concrete at the time the stamp was applied, the design of the stamp, and how far it was pushed into the concrete. Surface cracks like this are not desired as they provide an opening for moisture to penetrate, potentially causing premature floor deterioration due to freeze-thaw action.

Concrete that has a rough, abrasive final finish after stamping can be remediated by dragging concrete blocks behind a tractor or skid-steer loader for several passes. This process should be done before the problem areas are populated with cows. Walking on the concrete floor comfortably with bare feet is a good way to determine if the floor will be acceptable for cows.

### Anti-Slip Aggregates

Milking center cow decks, areas in and around remotely located restraint facilities, and cattle loading chutes are all locations where cows and people interact. This interaction may be accepted, or at least tolerated by a cow, depending on several factors including her past experiences in the given area. In certain circumstances, human contact or perceived human contact by the cow may frighten her, and she may try to flee from the objectionable area. The lack of confident footing while attempting to flee may cause hoof slip and trigger additional anxiety. For this reason, extra attention needs to be dedicated to providing adequate flooring in these areas.

Welchert and Armstrong (1992) present one possible solution for providing enhanced traction in potentially high anxiety areas. They describe how to top newly placed, uncured concrete with a dry shake mix composed of three parts anti-slip aggregates (aluminum oxide or corundum) and one part Portland cement by weight. Welchert and Armstrong (1992) give a complete description of how to accomplish this process. A brief synopsis of the procedure is as follows. After the shake mix is prepared, it is hand applied at a rate of 60 to 100 pounds per 100 square feet of floor space after the concrete has been placed, screeded and floated, and surface water has disappeared. Subsequent to application, the mix is power floated lightly to partially imbed the anti-slip aggregates and then steel trowelled until the aggregate surface is uniform and lightly textured.

When applied as prescribed, Welchert and Armstrong (1992) report that the resulting floor surface will be non-slip and highly wear resistant. Floor life is estimated to be 20 years as opposed to seven years for regular floors.

One of the author's experiences with the application of a dry shake mix resulted in two cow decks in a new milking center with an unacceptable level of traction. The reason for the poor outcome can be attributed to the finishing crew's inexperience with the dry shake mix application process. This is a sensitive process and only crews experienced with applying a dry shake mix for the intended final application should be used. Otherwise, an extremely hard floor surface will most likely result that offers no enhancement of traction over a hard troweled concrete floor.

It should be emphasized that a dry shake mix should not be used in freestall alleys or other areas frequented by cows several hours per day. Experience has shown that excessive wear of cows' hooves will result causing the need to prematurely cull many animals from the herd soon after barn population (Martin, 1999).

### Epoxy Floor Coatings

A carefully selected epoxy flooring system, which is appropriate for the application, can be employed to improve cow traction. Epoxy flooring is most applicable as a surface rejuvenation agent to relatively small areas that can be made free of cow traffic for a few consecutive days. Ample time is needed to properly prepare the existing floor (which is crucial to final product durability), apply the product, and allow for proper curing. Additionally, the cost normally associated with an appropriate quality epoxy flooring material is usually high and hinders its use on a wide-scale basis.

Cow decks in milking centers that operate less than 12 hours per day are the primary candidates for installing an epoxy flooring system. The epoxy coating works well for this application since it can be cleanly installed around the structural support post for each milking stall. To facilitate installation, cows can be milked on one side of the parlor while work is undertaken on the other side. After the first side is completed, milking sides can be switched and the other side can be treated.

The U.S. Naval Academy dairy, located outside of Annapolis, Maryland, installed an epoxy flooring system in their milking parlor to remedy poor floor conditions in about 1982. In fall 1995, it was noted that the floor appeared to be holding up well. The herdsman reported that the cows had experienced no significant slippage problems since the epoxy floor was originally installed.

When considering the use of an epoxy flooring system, contractors and producers must do their homework to ensure that the product they are considering will provide a cow-friendly surface. It is recommended that a manufacturer's product specialist be consulted to discuss the application before a final product is chosen. Strict adherence to the manufacturer's recommended surface preparation and product application procedures are required to achieve a durable final product.

### Construction Considerations

Concrete slabs-on-grade constructed for use as alleys and walkways in cow barns need to be designed and constructed following good concrete practices. Poorly designed and/or constructed slabs will fall short in characteristics that make it cow-friendly initially or over time.

Concrete slabs-on-grade are only as good as the sub base material they are constructed over. Well-compacted gravel fill material with a minimum depth of 8 inches is generally recommended as a sub base material. A sub base serves to provide more uniform support for the slab than if it were carried directly on the natural ground, and to improve the drainage of water from beneath the slab, particularly important to locations subject to freezing and thawing.

Concrete should be procured from a ready-mix plant that uses a mix design that has been laboratory tested. Minimal water is needed for hydration of Portland cement, and additional water should not be added at the construction site as excess water will reduce the final strength and durability of the concrete. Concrete with a slump of 4

inches or less is recommended. If additional workability is desired by the concrete crew, the use of a concrete admixture specially formulated to enhance workability without sacrificing final strength is recommended.

Concrete slabs need to be reinforced to resist loading, restrained shrinkage, and thermal displacements. The addition of Fibermesh<sup>®</sup> reinforcement to readi-mix concrete is a contractor friendly and a very successful way to provide needed reinforcement. Fibermesh<sup>®</sup> is essentially polypropylene fibers that are hair-like in nature. Field experience has shown that the use of Fibermesh<sup>®</sup> as a reinforcing material outperforms woven wire mesh with respect to labor required for installation and slab crack control.

After concrete is placed, it should be cured for 5 days by preventing moisture from escaping. Several methods can be used, but the most popular are covering the top and exposed edges of the slab with a plastic film membrane or applying a spray-on sealer. Other measures are needed to provide proper curing conditions in hot and freezing conditions (see PCA, 1979).

Concrete alleys in freestall barns are of sufficient length and are placed in such a manner that joints are required. Three types of joints are used when constructing most concrete slabs-on-grade: expansion joints, contraction joints, and construction joints.

### *Expansion Joints*

Expansion joints, sometimes called isolation joints, permit movement between an alley slab and fixed elements such as water trough bases. They are also generally used around structural columns to avoid uncontrolled cracking of the slab over the column base. Typically a compressible material of about ¾ inch thickness is placed between the slab and the fixed member, as shown in the Figure 3, and a joint sealing compound is placed over the expansion material after the after the slab is constructed.

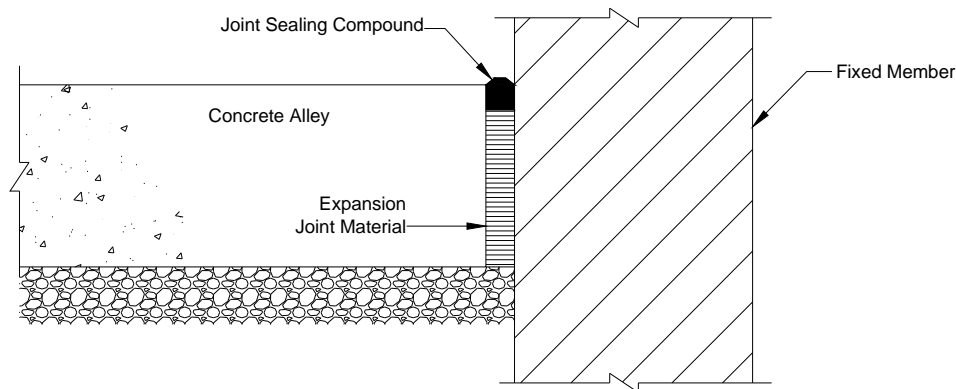
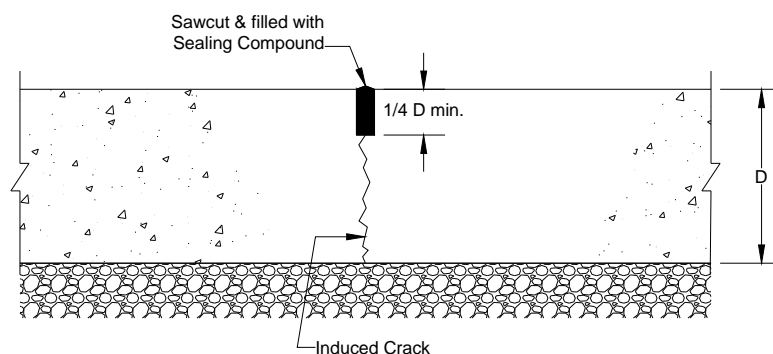

**Figure 3. Expansion joint located between a barn alley and a fixed part of the barn such as a structural column.**

### *Contraction Joints*

When concrete cures (hardens) it shrinks. As it shrinks, tension is created in slab-on-grades due to the frictional resistance developed between the bottom of the slab and its gravel subbase material. Tension is also created in the slab with low temperatures due

to contraction. Concrete is very weak in tension compared to when loaded in compression, resulting in slab cracking. Contraction (crack control) joints are used to insure that shrinkage cracks will be straight, in a regular pattern and protected from the elements. They are usually constructed by saw-cutting the slab within one or two days after concrete placement to a depth of about  $\frac{1}{4}$  of the total slab thickness, as shown in Figure 4. A liquid sealer is poured in the sawcut to prevent moisture from penetrating the crack and causing freeze-thaw damage. Slab reinforcement, if used, is usually continued without interruption across contraction joints. They may be doweled as well, to improve load transfer. Contraction joints are best located at intervals of structural post spacing since alley slabs will tend to crack at post locations (if the slab is placed adjacent to a building column) and are cut laterally across the slab. The maximum spacing between contraction joints is generally recommended to be no more than 20 feet.



**Figure 4. Contraction joint cut into a concrete alley and filled with a flexible liquid sealer.**

### *Construction Joints*

Construction joints are required wherever operations must be discontinued and later resumed. A true construction joint permits neither vertical nor horizontal movement between slab sections, and must usually be provided with tie bars and possibly a keyway as well. Because such joints are troublesome and expensive to construct, they are often avoided by terminating the work at expansion or contraction joints. A contraction joint used for this purpose should be provided with a shear key.

### **Pre-Cast Concrete Slatted Floors**

Pre-cast concrete slatted floors (slats) were primarily developed to reduce the amount of daily labor required to clean barn alleys and as a means to passively transfer liquid manure directly to a storage or gravity collection gutter located immediately below the barn alley. Slats have been used in most cow-frequented areas associated with confined housing systems including alleys between rows of stalls, adjacent to feeding surfaces, transfer lanes, and in milking center holding areas. Additionally, some producers locate slats at the ends of poured-in-place concrete alleys with the intention of using them as scraped manure drop sites. However, slats are not designed for this application and therefore this practice is not recommended. The relatively large volume of manure deposited in an alley will not effectively drop through the few narrow slots of a slatted floor located at the alley's end. A 8 to 10 inch wide continuous slot positioned

transversely in each alley will provide adequate space for scraped manure to drop through into a storage pit or gravity flow pipe located below.

Slats are available in two basic configurations: conventional slats & waffle slats. McFarland (1994) reports that conventional slats have a 1-3/4 to 2 inch slotted opening that spans the width of an alley, and between each slot is a 6 to 8 inch wide tread. The MidWest Plan Service Livestock Waste Facilities Handbook (1993) states that the distance between slats for dairy cows should be 1-1/2 to 1-3/4 inches. Albright (1995) and Kirchner and Boxberger (1987) recommend that a slot width should not exceed 1-1/4 inches with a maximum tread width of 3-1/4 inches, as these dimensions avoid excessive pressure on the cow's sole and help to prevent feces build-up on the slats.

A more recent slatted floor configuration, called waffle slats, is popular in Pennsylvania and other areas of the country. This design uses a series of openings approximately 1-3/4 inches by 8 inches spaced about 3 inches lengthwise and 5 to 6 inches apart (McFarland, 1994). An isometric drawing of a waffle slat floor section is shown in Figure 5.

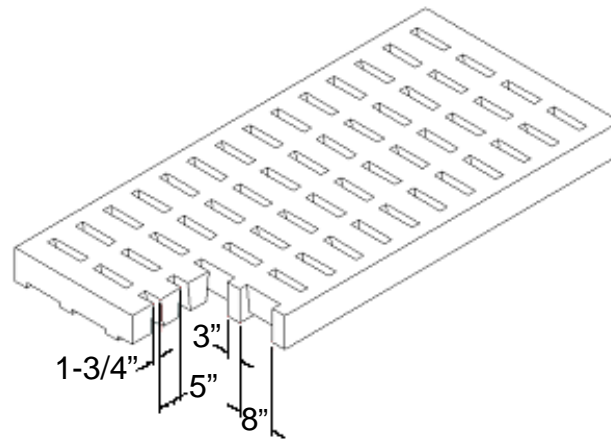

**Figure 5. Waffle slat floor section.**

Little conclusive research appears to exist relative to the impact of slats on foot health and cow behavior. Reports suggest that slats can cause foot problems and reduce assertive behavior resulting in less estrous detection. On the other hand, they have been shown to lower the incidence of lameness due to interdigital dermatitis when compared to solid floors. Observation has shown that when given a choice cows prefer to walk on solid flooring or floors covered with a rubber surface than on slatted flooring.

### **Alternative Flooring Surfaces**

Like people, foot and leg stress increases for cows when they stand on a concrete surface for extended periods of time. Standing on concrete is directly related to the development of hoof lesions (Bergsten, 1988). Many producers who have confinement facilities recognize this fact and usually try to give cows a reprieve from concrete by moving them to managed grassed areas or to earthen lots, when environmentally appropriate, during the dry period. This practice has been shown to be beneficial to

overall foot and leg health. However, the level of dairy animal confinement will most likely continue to increase with time due to economic and environmental factors. Some form of an alternative flooring surface may be a large component of the overall solution that is needed to provide a satisfactory level of foot and leg health and improve cow welfare for lifelong confined cattle.

Guard (2000) reports that claws of confined dairy cattle are commonly shaped in less than desirable forms, and misshapen claws will experience extreme localized pressures created by unforgiving surfaces. High pressures are reported to contribute greatly to damage of underlying hoof structures. Durable flooring surfaces that are forgiving and conform to the cow's hoof and are economical to install should be considered. Guard (2000) suggests barn floors should be surfaced with something other than concrete and that, combined with routine trimming, may prevent many cases of severe lameness.

Perhaps the initial reason many producers employed alternative flooring surfaces was to increase cow comfort at the feed bunk and hope that dry matter intake would correspondingly increase. Consequently, many producers are installing rubber belting in a 6-foot wide portion of the scrape alley adjacent to the feed bunk. One thought may be that perhaps cows would stand longer at the feed bunk and thus would be tempted to take that extra mouthful of food. Research is needed to determine the potential economic gain of this practice.

Alternative flooring surfaces are usually best installed flush with adjacent concrete surfaces by recessing the floor where the product is to be placed. Otherwise, adjustments will need to be made to manure scraper blades to accommodate an uneven alley if such manure removal systems are employed. Alternatively, rubber floor surfaces can be surface mounted at the feeding area and as a designated walking strip if manure is removed by a flush system or if the rubber covers the entire alley. These various locations and placements for installing rubber flooring are shown in Figure 6.

When evaluating whether to cover part or all of the concrete alleys with rubber flooring little research is available to aid in making this decision. Observation has shown that cows prefer to walk on rubber flooring instead of concrete, to the point where cow flow is hampered due to cows waiting to gain access to the rubber-floored portion of the alley. From a capital cost standpoint, rubber flooring cost approximately 10 times as much as grooving concrete (assuming a concrete floor is required in both instances). If the concrete alley is recessed to receive a rubber floor, an additional construction labor cost is incurred for the extra concrete forming required. Approximate cost for each additional form board erection and subsequent pour needed beyond those required for a normal alley is \$1.00 per linear foot.

#### Required Characteristics of Alternative Flooring Materials

Materials installed to enhance cow comfort and well-being must also be capable of withstanding the barn's many environmental factors. Flooring materials are subjected to repetitive compressive loads from cows' hooves and manure removal and bedding delivery equipment. Turning cows and equipment create torsional loads. Shear loads

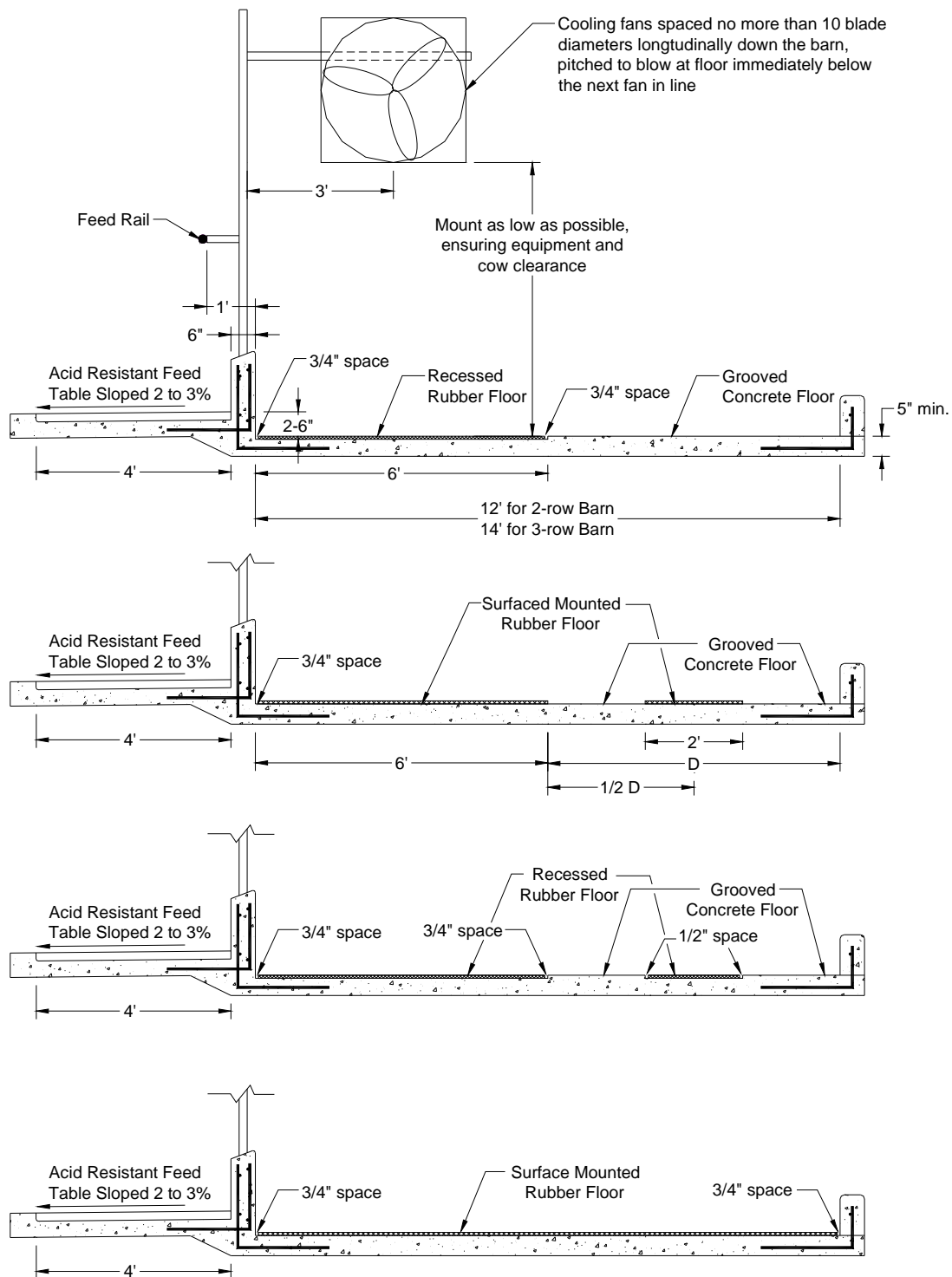

**Figure 6. Various locations for placement of rubber flooring surfaces. From top to bottom: surface mounted for the first six feet adjacent to the feeding curb, surface mounted at the feeding curb and additionally a two foot wide designated walking strip centrally located, flush mounted for the feeding area and designated walking area, and surface mounted covering the width of the alley.**

are developed when cows and equipment move across the floor. Temperature variations can cause thermal expansion and contraction. Automatic alley scrapers and skid-steer loader blades cause abrasion forces when they pass over a floor. Skid-steer loaders used when bedding stalls probably exert the most force on a floor surface due to the short, quick turns performed by the operator. Experience has shown that most rubber flooring products fail as a result of material failure around mechanical fasteners.

#### Alternative Flooring Material Options

Flooring alternatives to a traditional concrete surface include, but are not limited to, reclaimed rubber belting, rolled rubber flooring, rubber mats, and poured-in-place rubber flooring. All options require a concrete or another non-forgiving base material to provide support and a means to anchor the product. These alternative flooring products are most easily installed during new construction but sometimes can also be retrofitted into existing facilities with various degrees of preparation effort. Each option is discussed below.

##### *Reclaimed Rubber Belting*

Much of the rubber belting used in dairy barns has been reclaimed from the mining industry where it was once used as aggregate conveyor belt. Because of the varying nature of the belts relative to the source manufacturer and their original application, reclaimed rubber belting marketed to the dairy producer can have varying levels of hardness. Jackson (1999) reported the A-shore scale durometer reading is typically between 70 and 85 for most reclaimed belting that is being used for floor surfaces. The thickness of the carbon steel reinforced belt varies between 3/4 and 1-1/4 inches depending on the original manufacturer of the material. The heavy-duty nature of the belting allows it to hold up very well in a barn environment when properly installed. In a limited case, the metal reinforcing cables had been pulled from a section of the belt resulting in a potentially hazardous situation for the cows.

Belting can be custom cut in various widths and lengths to meet particular needs and is delivered to the project site in large rolls. Additional traction may be obtained by grooving the belt material, and this can be performed by the reclaimed belting supplier. Personal experience has shown that non-grooved belting topped with urine and manure can be slick.

The market price for grooved rubber belting is approximately \$2.75 per square foot (freight and installation cost are extra).

##### *Rolled Rubber Flooring*

Rolled rubber flooring is similar to the rubber belting discussed above, but it is not a surplus product. Several manufacturers are currently producing this material for the dairy industry. One manufacturer's product is composed of 40 percent post-consumer, 60 percent post-industrial recycled material that is fiber reinforced with nylon/polyester chords. The fiber reinforcement makes this product easier to cut in the field than the metal cable reinforced belting. Another advantage of this product is that its thickness and hardness is more consistent from roll to roll, which is not necessarily the case with

using reclaimed belting. The durometer reading for one product is reported by the manufacturer to be  $80 \pm 5$  on the A-shore scale. This indicates that this material is about the same relative hardness as the reclaimed belting offering, about the same level of resiliency per unit thickness. Their standard roll dimensions are 1/2 inch thick, 4 feet wide and 150 feet long. Another manufacturer sells a rolled product that is manufactured with a high percentage of virgin rubber. Virgin rubber products seem to be more durable in a barn environment than those comprised of mostly recycled materials.

A ball park price for the rolled rubber flooring material is about the same as for reclaimed rubber belting (between \$2.50 and \$2.75 per sq. ft.). Products that use a percentage of virgin rubber are usually higher.

#### *Rubber Mats*

Rubber mats are many times identical in composition to rolled rubber flooring if produced from the same manufacturer. Mats sizes are typically available in either rectangular or square configurations with dimensions ranging from 4 to 6 feet. Some mats are puzzle cut on the ends with a water jet cutting tool at the factory. Both the square cut end and the puzzle cut end need to be secured to a base material to ensure they remain in place.

#### *Constructed In-Place Rubber Floor*

Another consideration for providing a resilient surface for cows is a constructed in-place rubber floor. This type of flooring material is comparable to that used in athletic running tracks found at some athletic facilities. Such surfaces are highly resilient. Contacts made to a few major material suppliers and installation contractors revealed that neither have provided or installed their materials for a dairy housing application, but they believe that their floors should be able to endure the environmental factors found in a barn. Contacts were quick to mention that they routinely installed their products in horse stalls and in riding arenas and that product service has met customer expectations. Much of the following information was obtained by discussing the application of the contact's product specifically to the dairy industry.

In general, installing a constructed in-place rubber floor is similar to pouring a concrete slab-on-grade. Ground post-consumer rubber (aggregates) and a urethane resin (Portland cement and water) are proportioned and mixed together in a stationary batch mixer. The resulting product is placed between forms, screeded to the desired depth, troweled, and finally cured before putting it into service. The material placement process can be performed manually for smaller jobs or with special paving equipment that lays the material in 11-foot wide strips for larger projects. Like concrete, this process has optimum temperature and humidity ranges that must exist in order to obtain a quality final product.

Application thickness can vary between 1/2 to 1-1/2 inches. With a concrete base, one installer indicated an application of 1/2 inch is sufficient for horse stalls. If compacted stone is solely used as a base material, a 1-1/2 thick rubber floor is needed. When the

product is applied properly to a clean, moisture free base and has cured, contacts indicate that it should stick to the base indefinitely. A urethane sealer can be used to seal the top of the floor after it has cured, enhancing wear resistance and preventing moisture penetration.

Initial cost and lack of a dairy application proven product are the prevailing reasons why dairy producers have avoided using it. One estimated price to install a 1/2 inch thick floor in all alleys of a new 200-foot long 6-row freestall barn was \$2.75 per square foot. A 1-1/2 inch thick application was \$5.40 per square foot. A closer look at the cost of the raw products indicate that the material needed to construct a 1/2 inch thick floor should be able to be purchased for around \$1.00 per sq. ft. (Jackson, 1999). The high price quotes are comparable to the prices acceptable to the equine industry.

While this type of rubber flooring system has not been proven in the dairy industry, it appears to be the type of flooring system that may meet the needs of the cows.

#### Securing Rubber Flooring Products

The following paragraphs pertain to rolled and sheet rubber flooring materials.

Securing of rubber floors to a substrate is commonly done with mechanical fasteners (hardened nails). Fasteners need to be highly resistive to the corrosive nature of urine and manure. Stainless steel fasteners will outlast carbon steel fasteners. However, experience has shown that most rubber floors will fail before the fastener sufficiently corrodes to the point of failure. In the case of floor failure, usually the rubber material around the fastener fails and not the fastener itself. Manufacturers of rubber products for barn flooring should consider reinforcing the area around the fastening sites in order to better endure applied loads.

Flooring installation contractors should follow flooring manufacturing or supplier recommendations, when they exist, when securing rubber floors in place. One supplier suggests using corrosion resistant nails placed 12 to 16 inches on center along the rubber floor perimeter. It is important to slightly counter-sink mechanical fasteners into the rubber floor so puncture or bruising of a cow's sole is precluded. Rubber floors that are more resilient than others will require a greater counter sink depth since they will deform greater under cow foot loading. An angled seam at each joint location is suggested to better resist applied forces from tractor blades, skid-steer loaders, or mechanical alley scrapers.

#### Alternative Flooring Questions

All new products available to the dairy producer generate several questions regarding their merit and value as an addition to the farm business. Alternative flooring surfaces are no exception. The author is not aware of any data directly addressing the effects of alternative flooring on lameness or dry matter intake for freestall housed cows that can be used to assist with making a purchase decision. However, in a related study area, Bergsten (1994) observed that cows in commercial dairy herds tied in stalls equipped with rubber mats had significantly less severe sole hemorrhages than those tied in

concrete stalls. Laminitis-related disorders have been found to decrease with rubber mats in tie stalls by both Bergsten (1994) and Thysen (1987). Also, numerous anecdotal reports by dairy producers and observations by the author indicate that freestall cows prefer standing and walking on resilient surfaces when given a choice. Guard (2000) believes that rubber flooring surfaces are a step in the right direction. Unanswered questions include the following.

- Which available surface(s) best meets the requirements?
- Does using alternative flooring surfaces solely at the feed bunk offer sufficient reprieve from concrete?
- How thick should the alternative flooring surface be?
- What kind of return on investment does an alternative flooring surface provide?

### **Floor Slope**

The floors used by dairy cows are usually sloped in order to provide adequate drainage of surface water runoff or to facilitate the connection of two different cow use areas with unequal elevations. Sloping barn alleys provide drainage of urine, rainwater, and excesses sprinkling water, if such a heat stress relief system is in place. Alleys are also sloped to facilitate planned or future flushing operations and to possibly conform to existing topography. Sloping of barn alleys is not possible if gravity flow waterers are used. All waterers need to be at the same elevation for the water delivery system to function properly.

Barns connected to a milking center may have sloped walkways depending on the existing elevations and the configuration and layout of each building. As the magnitude of any sloped floor increases, the level of cow slip hazard correspondingly increases. The range and optimum level of slope for different cow-frequented areas on a dairy farm is provided in Table 1. Most of the values found in the table were initially presented by Welchert and Armstrong (1992) with a few of them updated by the author.

**Table 1. Floor Slope Specifications for Various Cow Areas Frequented on a Dairy Farm.**

<b>Cow Frequented Area</b>	<b>Range</b>	<b>Optimum</b>
Parlor Cow Decks & Exit Area	1 to 3 percent	1.5 percent
Parlor Holding Area	1.5 to 6 percent	2 to 3 percent
Feedline & Freestall Alleys	1 to 4 percent	1.5 to 3 percent
Flushed Alleys	1 to 4 percent	3 percent

The maximum slope in any cow transfer lane or walkway should not exceed 6 percent. If specific circumstances require that walkways must be greater than 6 percent to create a connection between two areas, install 6 to 8 inch steps placed at least 3 feet apart. The treads may be sloped no more than 1.5 percent to help achieve the required elevation change.

### **Construction Specifications for Cow Flooring**

Shortcomings in flooring for dairy cattle can be minimized by following complete construction specifications that clearly articulate in writing the required materials, construction procedures, and finish for floors. Several such specifications may be needed depending on the size of the overall project. For example, flooring specifications for the freestall barn will be somewhat different than those for a loading ramp. (The latter will probably require a more aggressive flooring surface as cows will be subjected to more stress and more susceptible to slip.) Contractual documents should reference flooring specifications (in fact, all specifications for the job).

### **Summary**

Modern dairy confinement facilities are housing cows for much if not all of their entire lives. Concrete is the prevalent flooring surface in dairy barns and shelters at this time. Concrete must be properly grooved or patterned to provide confident footing for cows. Ragged groove edges and rough finished surfaces are abrasive to cows hooves and must be avoided. Even a properly finished and grooved concrete surface causes excessive stress on cows' feet and legs due to its unforgiving nature. Alternative flooring surface options like rubber belting, rubber mats, and constructed in-place rubber floors are more resilient than concrete and seem to offer a degree of relief to the cows. Research is needed to determine the optimum alternative flooring surfaces for cows and how much of it needs to be installed in a barn.

Whatever flooring surfaces is chosen by the dairy producer for a new facility, the desired end product must be clearly understood by the contractor to help ensure an acceptable product is provided. Contractual documents should clearly specify type of flooring to be provided by the contractor along with minimum levels of acceptance. Floors that do not conform to the specifications should not be accepted by the dairy producer until shortcomings have been remedied.

## References and Additional Information

- Albright, J.L. 1995. Flooring in Dairy Cattle Facilities. Proceeding from the Animal Behavior and the Design of Livestock and Poultry Systems International Conference. NRAES-84. Northeast Regional Agricultural Engineering Service. Cornell University, Ithaca, New York.
- Albright, J.L. and C.W. Alliston. 1971. Effects of Varying the Environment Upon the Performance of Dairy Cattle. *Journal Animal Science*. 32:566-577.
- Bee, D.J. 1986. Observation on Lameness in a Hampshire (UK) Practice. In: Proceedings of the 5<sup>th</sup> International Symposium of the Disorders of the Ruminant Digit. August 24-25. Ireland
- Bergsten, C. 1988. Sole Bruising as an Indicator of Laminitis in Cattle. A Field Study. In: Proceedings of the XVth World Buiatries Congress, Palma de Mallorca.
- Bergsten, C. 1994. Hemorrhages of the sole horn of dairy cows as a retrospective indicator of laminitis: An epidemiological study. *Acta Vet Scand* 35:55.
- Bray, D.R. 1998. Cow Comfort at the Feeding Area. Proceedings from the Dairy Feeding Systems Management, Components, and Nutrients Conference. NRAES 116. Natural Resource, Agriculture, and Engineering Service. Cornell University, Ithaca, New York.
- Dewes, H.F. 1978. Some Aspects of Lameness in Dairy Herds. *New Zealand Veterinary Journal*. 26:147-8 & 157-9.
- Dumelow, J. 1993. Simulating the Cattle Foot/Floor Interaction to Develop Improved Skid Resistant Floors. *Livestock Environment IV*. Proceedings of the Forth International Livestock Environment Symposium. American Society of Agricultural Engineers.
- Guard, C. 2000. Environmental Risk Factors Contributing to Lameness in Dairy Cattle. Proceedings from the Dairy Housing and Equipment Systems Conference. NRAES-129. Natural Resource, Agriculture, and Engineering Service. Cornell University, Ithaca, New York.
- Graves, R.E., D.F. McFarland, and J.T. Tyson. 1997. *Penn State Dairy Housing Plans* (NRAES-85). Second Edition. Northeast Regional Agricultural Engineering Service. Cornell University, Ithaca, New York.
- Jackson, W.J. 1999. Personal Communication. Private Consultant. Elma, New York.
- Kirchner, M. and J. Boxberger. 1987. Loading of the Claws and the Consequences for the Design of Slatted Floor. In: *Cattle Housing Systems, Lameness and Behavior*. Proceedings of Comm of Europe Communities, Brussels. Eds HK Wierenga & DJ Peterse. Martinus Nijhoff Publishers, Dordrecht.
- Martin, J.G. 1999. Personal Communication. Dairy Housing Design Engineer. Gainesville, Florida.

McFarland, D.F. 1994. Designing Dairy Housing For Convenient Animal Handling, Feed Delivery, and Manure Collection. *Dairy Systems for the 21<sup>st</sup> Century*. Proceedings of the Third International Dairy Housing Conference. American Society of Agricultural Engineers.

MWPS, 2000. *Dairy Freestall Housing and Equipment* (MWPS - 7). Seventh Edition. Midwest Plan Service, Iowa State University, Ames, Iowa.

MWPS, 1993. *Livestock Waste Facilities Handbook* (MWPS - 18). Third Edition. Midwest Plan Service, Iowa State University, Ames, Iowa.

PCA. 1979. *Design and Control of Concrete Mixtures*. Portland Cement Association. Skokie, Illinois, 60077.

Thyssen, I. 1987. The Influence of Housing Systems on Claw Disorders with Dairy Cows. In: *Cattle Housing Systems, Lameness and Behavior*. Proceedings of Comm of Europe Communities, Brussels. Eds HK Wierenga & DJ Peterse. Martinus Nijhoff Publishers, Dordrecht.

Thyssen, I. 1987. Foot and leg disorders in dairy cattle in different housing systems. In: Wierenga HK, Peterse DJ (eds): *Cattle Housing Systems, Lameness and Behavior*. Dordrecht, Martinus Nijhoff Publishers.

Welchert, W.T. and DV. Armstrong. 1992. Anit-Slip Concrete Floor Specifications. Proceedings from the National Milking Center Design Conference. NRAES-66. Northeast Regional Agricultural Engineering Service. Cornell University, Ithaca, New York.